

## Model 2075WCOL WINE CAPTAIN®

See Overlay Door Panel Preparation Instructions

An Échelon full overlay frame model WINE CAPTAIN® wine storage unit with 48 bottle capacity.

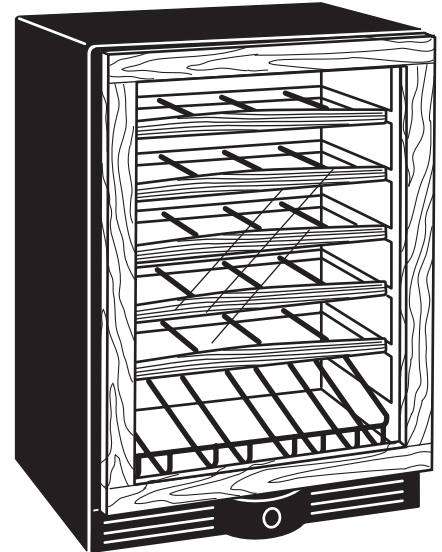
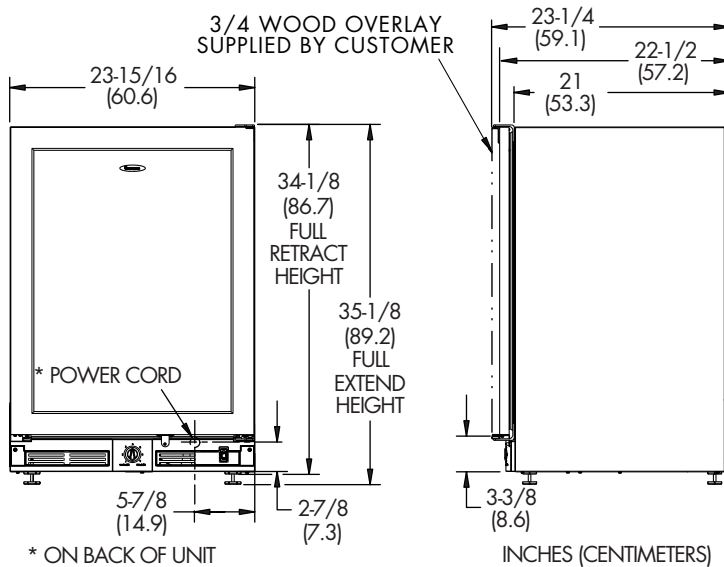

## SUPERIOR FEATURES OF ÉCHELON™

- 1. The Wine Captain door is designed to accept a 3/4 inch thick, 2-1/4 inch wide full overlay doorframe.\*\***

**BENEFIT:** Provides a fully integrated appearance with surrounding cabinets. Overlay frame is easily attached to the door.
- 2. Three temperature zones within one cabinet**

**BENEFIT:** Ensures that the specific type of wine is maintained at the proper temperature. Sparkling wines such as champagnes are stored at the bottom and maintain a product temperature of approximately 45° F (7° C). White wines are stored in the middle section of the cabinet and maintain a product temperature of 50-55° F (10-12° C). Red wines are stored at the top of the cabinet and maintain a product temperature of approximately 60° F (15° C).
- 3. Five sturdy, slide out, fully extendable wine racks**

**BENEFIT:** Easy access to all wine bottles especially those located on the rear portion of the rack. Bottles are stored in a horizontal position keeping the cork moist to prevent air from entering the bottle.
- 4. Black vinyl wine racks**

**BENEFIT:** The black vinyl blends well with the wine bottles therefore placing greater visual emphasis on the wine itself. The vinyl coating on the racks also "grip" the wine bottles more securely.

\*\* A full overlay wood frame must be installed on this model. Overlay frame not supplied by U-Line. For detailed overlay preparation and installation instructions please contact the U-Line website at [www.u-line.com](http://www.u-line.com) prior to ordering frame from your cabinetmaker. For further information see our User's Manual.

# SUPERIOR FEATURES OF ÉCHELON™

---

5. **The wine racks have a contoured, wooden front facing**

**BENEFIT:** The contoured front facing adds an upscale appearance. The wood is maple and is treated for durability and for use in a temperature controlled environment. The wood facing may be stained or replaced in its entirety by the end user with other wood products or such products as Corian®, Sandstone or other like products.

6. **Bottom fixed "Wine Display Rack" - EXCLUSIVE U-LINE feature**

**BENEFIT:** Displays wine bottles at an approximate 40 degree angle. The "Display Rack" holds eight bottles clearly displaying the labels of four bottles.

7. **Tinted, thermal glass door**

**BENEFIT:** Protects your wines from potentially harmful light rays.

8. **Field reversible door**

**BENEFIT:** Greater flexibility where the unit can be installed and allows for side-by-side applications. **Please note** that after the full overlay frame is installed, the door swing is no longer reversible.

9. **Forty-eight (48) bottle capacity**

**BENEFIT:** Generous wine storage capacity.

10. **Interior light which can remain either "off" or "on" when the door is closed. The interior light will automatically illuminate when the door is opened.**

**BENEFIT:** For those special occasions when you invite guests to dine, you may attractively "display" your wine collection with the door closed.

11. **Self closing door hinges are engaged when door is open approximately 8-10 inches**

**BENEFIT:** Ensures a positive door seal and prevents door bounce back.

12. **"L" shaped door hinges**

**BENEFIT:** This hinge design provides greater door support.

13. **Flat, recessed, front grille with "warmer/colder" control settings**

**BENEFIT:** Adjustable temperature control. Greater toe kick space. Easy to read molded temperature control settings. The grille shields the interior motor compartment and all electrical components from view.

---

## ADDITIONAL FEATURES

1. Vinyl clad steel cabinet (black)
2. Adjustable leveling legs

---

## BENEFITS

Textured, rich look. Resistant to scratching, peeling and flaking.

More precise under the counter fit, durable – factory installed.