



MPE-XC Single-Unit Control Panel (Shown with TWLC keypad/display mounted in door)



MPE Multi-Unit Control Panel Shown

TWLC System

The Tempered Water Logic Control (TWLC) is an advanced microprocessor circulated water chiller control system specifically designed for marine use. The TWLC system maximizes performance and provides the highest level of protection for the chillers, while supplying the user with important system information and easy access.

Each tempering unit has a dedicated power/logic board, and up to six P/L boards can be networked together to form an integrated system (controlling up to 6 chillers). This configuration allows operation of the chillers if the network or a P/L board has a failure. The P/L board is designed for easy replacement with plug-in terminal strips and RJ12 jacks. LEDs on the board help troubleshooting procedures, and a replaceable EPROM allows for software upgrades.

Interaction with the system is through the TWLC keypad/display. A simple 4-button keypad is used to change operation mode and system parameters, and navigate through the menus. A backlit LCD display supplies easy to read information about the system, including; water temperatures, operation mode, which chillers are running, and detailed fault information. Three small LEDs on the keypad clearly indicate Cool or Heat modes, and a unit fault. An alarm buzzer on the keypad can also signal a fault. Multiple TWLC keypads can be installed to allow remote system access.

One key feature of the TWLC system is that it can be connected to, and controlled by, an on-board computer with software that emulates the TWLC keypad/display. Alternatively, a modem can be connected to allow a remote computer to dial up and access the system. This could be used for remote troubleshooting by an authorized service agent.

The TWLC system operation is fully automatic. It senses how many units are connected and programs the temperature staging and the rotation of the units to pre-programmed parameters. The complete system operation and all available functions can be found in the TWLC manual. The TWLC offers simple operation and menu-driven selections. The default screen displays loop supply and return temperatures, mode of operation (cool or heat), and which chillers are running. Pressing any button takes you to the Main Menu where you can select the system mode (Off, Cool, Heat), or continue scrolling down to select one of the sub-menus.

When connecting to a computer or a modem, custom software is available that emulates the TWLC keypad/display on the computer screen. Navigating through the system with this software is identical to using the TWLC.

Features

- Up to 6 tempering units can be integrated into one network
- Keypad/Display has a 4-button control and a 4-line backlit LCD display
- Multiple keypad/displays can be used for remote access.
- Available in single-unit or multi-unit panels (single-unit panels can be connected for full-network operation)
- Multi-unit panels come with circuit breakers for compressor and pump control
- Chiller staging based on circulated water temperature
- Compressor rotation to equalize run time of each unit

- Compressor and pump time delay to prevent simultaneous starting
- Records and logs faults and run times

Advanced Options

- Connect to an on-board computer or modem
- Current transducers to monitor compressor and pump amperage
- Seawater temperature sensors
- Refrigerant pressure transducers
- Loop water and seawater pressure transducers
- Control an optional source of heat (electric immersion heater or fuel-fired boiler)

SINGLE-UNIT and MULTI-UNIT CONTROL PANELS

The TWLC system is available in 2 different control panel options, single-unit panels and multi-unit panels. Single-unit panels are less expensive than multi-unit panels and can often be fit in spaces where a large multi-unit panel won't fit. They are also typically in stock for quick delivery. Single-unit panels are often the answer for refit jobs where the vessel's power panel already has breakers for each chiller and pump.

Multi-unit panels are custom built for each system with circuit breakers and contactors for up to 6 chillers and the circulation and seawater pumps. Installation is easier than with single-unit panels because separate pump relays are not needed, all the network and high-voltage wiring is provided, and only one power input from the vessel is required. With all the P/L boards, breakers, relays, etc. in one location, a multi-unit panel is more convenient to the user.

Single-Unit Panels

The MPE-XC will work with either 230V 1-phase compressors, or 230V – 460V 3-phase compressors. The control circuit is 230V 1ph, and a separate power feed will be required on 380-460V systems. The MPE-VXC has the same features, but is for use with a variable frequency drive (VFD).

The MPE single-unit panel includes the P/L board, compressor contactor (or relay), 10 ft (3m) wire harness, control circuit fuses, and a short CNP cable to a TWLC keypad/display.

In addition to the MPE single-unit panels (one per chiller), the system will require: one TWLC keypad/display, CNP network cables (one per panel), pump relays (for circulation and seawater pumps), and one temperature sensor to monitor the common loop water supply. The TWLC keypad can be installed in the door of the panel, or installed remotely (with a CNP cable). Multiple TWLC keypads (up to one per board) can be installed if desired.

All of the optional inputs can be added to MPE single unit panels, and there is a location for a compressor current transducer in the panel. Temperature sensor wells are also available for the common loop water supply sensor, and for the seawater out sensors.

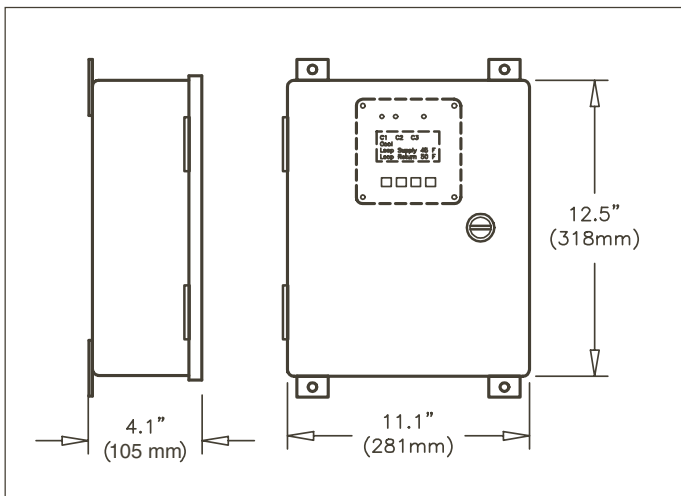

MPE-XC Single-Unit Control Dimensional Information

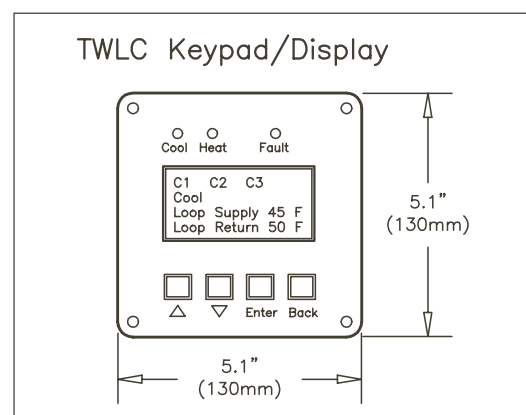

Tempered Water Logic Control Dimensions

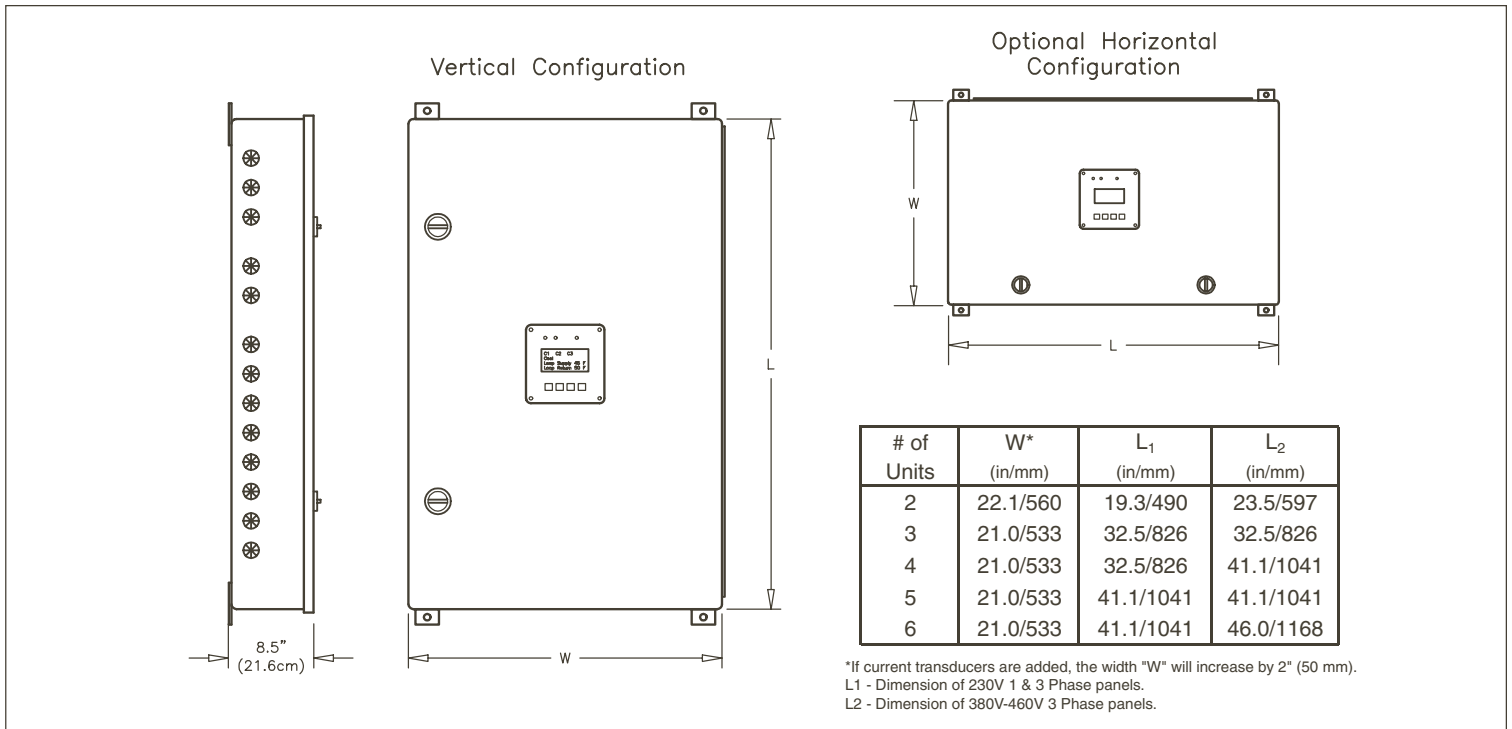

MPE Multi-Unit Control Panel Dimensional information

MPE Multi-Unit Panels

Custom multi-unit MPE panels are available that provide breakers and relays for the compressors and pumps all on one chassis. This can make installation easier because it allows the installer to bring in one power feed for the complete system, there are no separate pump relays to install, and many options can be built into the panel.

Each multi-unit panel includes a TWLC keypad mounted in the door, fusing for the control circuit, a transformer on 380-460V panels for the control power, and a wire harness to connect to the chillers.

Since each multi-panel is built custom, there are many options available:

- **Panel Orientation** – Can be built so the long dimension is vertical or horizontal.
- **Door Hinge** – The door can be hinged on the left or right sides of a vertical panel. On a horizontal panel the door is hinged on the top.
- **Spare Pump Switch** – Selector switches can be added for backup (spare) pumps.
- **Multiple Power Inputs** – Up to 3 power blocks can be installed to help divide the chiller and pump loads.
- **Electric Water Heater** – If an electric water heater is desired, the panel can be built with the appropriate breakers and contactors to control the heater.
- **Fault Output Relay** – A set of “dry” contacts can be installed to operate an alarm on the vessel’s monitoring system.
- **Longer Wire Harness** – The standard harness is 10 ft (3m) but longer harnesses are available, up to 30 ft (9m).
- **Frame Mounted Panel** – If a framed chiller is ordered, the panel can be mounted on the frame.

In addition to the options above, **two different upgrade packages** are available for multi-unit panels.

The Level 1 upgrade package adds current transducers for the compressors and pumps, seawater out temperature sensors in each chiller, a common seawater inlet temperature sensor, and the computer and modem adapters.

The Level 2 package includes all items in Level 1, plus: refrigerant high and low pressure transducers for each chiller, a seawater pressure transducer (to install on the discharge of the seawater pump) and a loop water pressure transducer (to install on the inlet of the loop water pump).

Other items that might be required are: a long CNP cable to install a remote TWLC keypad, a long CNP cable to route to a computer or modem, and temperature sensor wells.

FAULTS

The system monitors all the inputs and will display 12 different faults based on the information received. Each fault has a specific routine that protects the unit while helping to prevent nuisance faults. Some will generate a sustained shutdown, which must be reset from the TWLC keypad.

If a fault is sensed, the fault LED on the TWLC keypad will light (and the buzzer will sound, if activated) and the specific fault will be displayed on the LCD screen. The fault signal output on the P/L boards will also be powered.

The faults monitored by the system are:

- High Refrigerant Pressure
- Low Refrigerant Pressure
- Loop Water Flow Switch
- Loop Water Temperature Differential
- Loop Water High Temperature Limit
- Seawater Out Low Limit
- Seawater Temperature Differential
- Auxiliary Heater High Limit
- Temperature Sensor Fault
- Low Control Voltage
- Network Fault
- EPROM Error

INPUTS

Each P/L board has up to 14 inputs. The six standard inputs are listed in bold. The other inputs shown (#7-14) are optional, and are available in upgrade packages or can be added separately.

1. **Loop Water Return Temperature Sensor**
2. **Loop Water Out Temperature Sensor**
3. **Common Loop Water Supply Temperature Sensor**
4. **Flow Switch**
5. **High Pressure Switch** (or Pressure Transducer)
6. **Low Pressure Switch** (or Pressure Transducer)
7. Compressor Current Transducer
8. Loop Water Pump Current Transducer
9. Seawater Pump Current Transducer
10. Seawater Out Temperature Sensor
11. Common Seawater Inlet Temperature Sensor
12. Loop Water Pressure Transducer
13. Seawater Pressure Transducer
14. Auxiliary Heater Temperature Sensor

OUTPUTS

There are 6 outputs on each board. Each line voltage (115 or 230VAC) output is through a board-mounted triac which can control a relay or contactor.

1. **Compressor**
2. **Reversing Valve**
3. **Loop Water Pump**
4. **Seawater Pump**
5. **Aux. Heater**
6. **System Fault**

Dometic Corporation Environmental Systems

P.O. Box 15299 • Richmond, VA 23227-0699 USA • Phone: 804-746-1313 • Facsimile: 804-746-7248
2000 N. Andrews Ave. Ext. • Pompano Beach, FL 33069-1497 USA • Phone: 954-973-2477 • Facsimile: 954-979-4414
Fleets Industrial Estate • 26 Willis Way • Poole, Dorset BH15 3SU, England • Phone: +44(0)870 3306101 • Facsimile: +44(0)870 3306102
Email: sales@cruisair.com • Website: www.cruisair.com

Revised: 09-28-04 L-2057